

IG22W

HIGH FLOW ICE MACHINE WATER FILTER



For Cubers up to 1,450 lb/day

Rainfresh IG22W filter system is a two-stage water filtration system specifically designed to improve the quality of ice by reducing chlorine, bad tastes and odours in the water and protect ice machines from the damaging effects of sediment which can cause corrosion of metallic components and clogging of nozzles and solenoid valves. IG22W also protects ice machines from effects of scale build-up on evaporator plates. This reduces service costs and downtime substantially, leading to increased profits.

PROTECTS AGAINST

- Chlorine, taste and odour
- Scale build-up
- Sediment

IG22W is a double-stage system designed for ice machines that produce up to 1,450 lbs/day. It:

- Reduces chlorine, bad tastes and odours that can affect the taste of ice
- Reduces dirt, grit, sand and other fine particulates for clean ice cubes and flakes
- Features a polyphosphate feed to inhibit scale build-up in the ice machine

A water pressure gauge is included to monitor pressure variations and spikes. It also indicates cartridge plugging (when differential pressure exceeds 15 psi).



FEATURES & BENEFITS

- Reduces chlorine, taste and odour
- Reduces scale formation and sediment that cause frequent breakdowns of ice machines
- Extends life and reliability of ice machine
- Economical and easy to maintain

System Dimensions

Model	Unit Width	Unit Height	Unit Depth
IG22W*	19.5" (495 mm)	25" (635 mm)	6" (152 mm)

- * - a) For cold water use only. This product is for commercial use only.
 b) Do not use with water that is microbiologically unsafe or of unknown quality without adequate disinfection before or after the system.

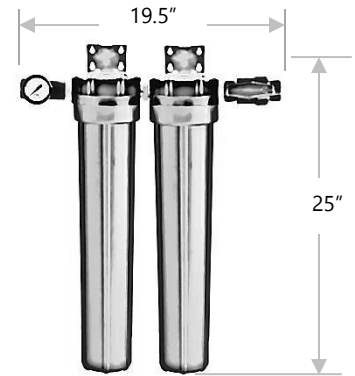

Operating Specifications

Inlet/Outlet Connections	: 3/4"
Max. Service Flow Rate	: 3.0 US GPM (11.3 LPM)
Max. Temperature	: 100 F (38°C)
Max. Pressure	: 100 psi (689 kPa)**

** If pressure surges or water hammer conditions exist, a pressure regulator and/or water hammer arrestor should be installed.

Cartridge Specifications

Replacement Filter	Function	Micron Rating	Cartridge Life (each)
AC20G05S	Reduction of chlorine, taste, odour and sediment. Inhibition of scale	5μ	4,000 US gal or 6 months [^]

[^]Cartridge life may vary with water quality and usage.

Limited 1 year warranty

Jan 2019



Envirogard Products Limited

446 Major Mackenzie Drive East,
 Richmond Hill, ON L4C 1J2, CANADA

Toll-free: 1 800 667 8072 ; **Tel:** (905) 884 9388; **Fax:** (905) 884 3532

E-Mail: info@rainfresh.ca ; **Web:** www.rainfresh.ca